



PSH-24V Conventional Smoke + Heat Detectors

Installation AND Maintenance Instructions

General Description

The model incorporates a state-of-the-art optical sensing chamber and an advanced microprocessor. The microprocessor allows the detector to automatically adjust its sensitivity back to the factory setting when it becomes more sensitive due to contaminants settling in its chamber.

The detector is designed to provide open area protection.

TYPICAL WIRING DIAGRAM

Figure 1(a) shows the typical wiring diagram of the multiple-station smoke detector system.

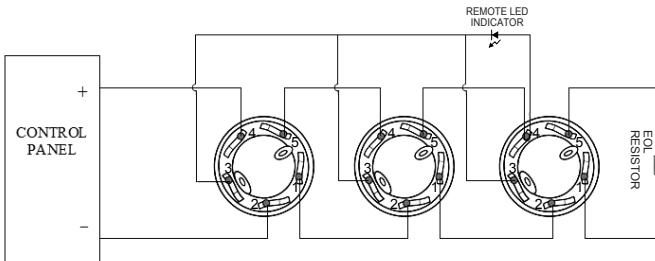

The wiring diagram of 2/3 wired LED remote indication

Do not place links between terminals 1,2 and 4,5 to provide wire continuity monitoring

Figure 1(b) shows the typical wiring diagram of the 4-wire multiple-station smoke detector system.

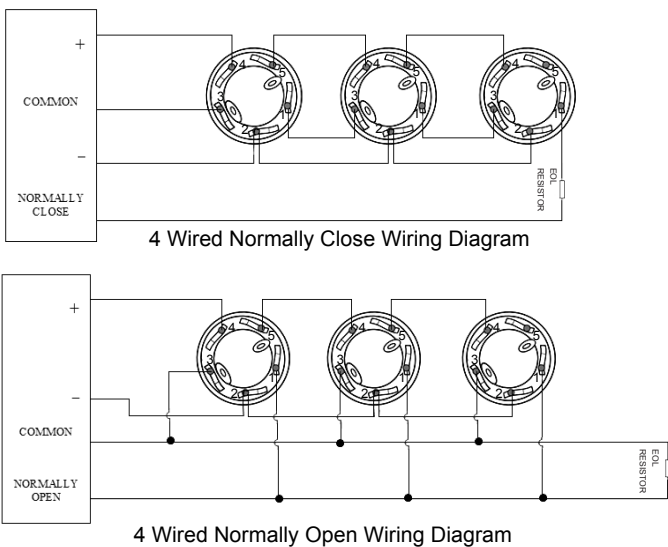

4 Wired Normally Close Wiring Diagram

4 Wired Normally Open Wiring Diagram

DO NOT PLACE LINKS BETWEEN THE WIRING POSITIONS OF TERMINALS 2 AND 4, 5 TO PROVIDE POWER SUPERVISION

Note: relay and the remote indicator could not be used at the same time

WARNING

TO PREVENT DETECTOR CONTAMINATION AND SUBSEQUENT WARRANTY CANCELLATION, THE SMOKE DETECTOR MUST REMAIN COVERED UNTIL THE AREA IS CLEAN AND DUST FREE.

INSTALLING THE BASE

- To insure proper installation of the detector head to the base, all the wires should be properly addressed at installation:
 - Position all the wires flat against terminals.
 - Fasten the wires away from connector terminals.
- If you use a jumper wire to connect the poles of terminal 2 and 3, 4 when testing the detector loop continuity, be sure to remove the jumper wire prior to the installation of the detector head.
- The end-of-line device shown in fig. 1(a) and 1(b) should be compatible with the control unit. The end-of-line supervisory relay used should be rated for the DC power voltage used.
- Open area smoke detectors are intended for mounting on a ceiling or a wall in accordance with the fire standard in your country.
- The base of the smoke detector can be mounted directly onto an electrical junction box such as an octagonal (75mm, 90mm or 100mm), a round (75mm), or a square (100mm) box without using any type of mechanical adapter.

INSTALLING THE HEAD

- Align the components as shown in Figure 2.
- Mate the detector head onto the base and twist clockwise to secure it.
- Do not install the detector head until the area is thoroughly cleaned of construction debris, dusts, etc.

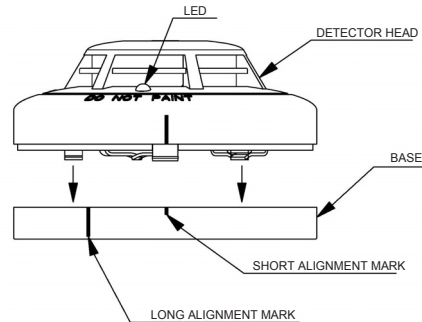

Fig. 2 Mating detector head onto base

Note: relay output of the device is fully isolated (Dry)

The following requirements are for which with relay output:

Rated load of relay: 1A@30VDC,

0.5A@125VAC .

TESTING

1. All the alarm signal services, releasing device and extinguisher system should be disengaged during the test period and must be re-engaged immediately at the conclusion of testing.
2. After energizing the detector head for approximately one minute, check to see the indicator red LED flashing once every 30 seconds. If red LED fails to flash, it indicates the non-functioning of the detector or faulty wiring. Re-check the wiring or replace the detector if necessary.
3. Allow smoke from a cotton wick or a test smoke aerosol to enter the detector-sensing chamber for at least 10 seconds. When sufficient smoke has entered the chamber, the detector will signal an alarm, this being visible by a continuous illumination of the Red LED. Reset each detector and/or control unit before attempting to test any additional detectors in the same zone. If the alarm fails in this step, it indicates a defective unit, which requires service.
3. Upon alarm immediately remove the heat source and check that the red LED of the detector is illuminated. Reset the detector from the control panel.
4. If detector fails to go into alarm mode within 30 seconds it is too insensitive and needs to be returned to the distributor for servicing.
5. After testing, check that the system is set for normal operation and notify the appropriate authorities that the testing operation is complete and the system is active again.

NOT SUITABLE FOR INSTALLATION IN AREAS WHERE AIR VELOCITIES EXCEED 600 meters/min

MAINTENANCE

The recommended minimum requirement for detector maintenance consists of an annual cleaning of dust from the detector head by using a vacuum cleaner cleaning program should be agreed to the individual environment in conformance with EN54-7:2000 and EN54-5:2000 standards.

CAUTION: DO NOT ATTEMPT TO DISASSEMBLY OF THE FACTORY SEALED SMOKE DETECTOR. THIS ASSEMBLY IS SEALED FOR YOUR PROTECTION AND IS NOT INTENDED TO BE OPENED FOR SERVICING BY USERS. OPENING THE DETECTOR HEAD WILL VOID THE WARRANTY.

HEAT SENSOR TESTING

The detector to be tested should be subject to a flow of warm air at a temperature of between 65°C and 80°C. (This requirement can be met by some domestic hair dryers).

Proceed as follows:

1. Switch on the warm airflow and check that temperature is correct and stable.
2. From a distance of several inches, direct the airflow at the guard protecting the thermistor. The detector should alarm within 30 seconds.

SPECIFICATION

Model	2/4 wire	Thermal	Voltage DC	Standby Current (Max.)	Alarm Current (Max.)	Surge Current (Max.)	Start-Up Time (Max.)	Permissible Current (Max.)	Frequency	Alarm contact	Base model
PSH-24V	2	57°C	15-35V	88µA	70mA	120µA	60 Seconds	80mA	2 Seconds	—	P/N870302